

THIS DRAWING IS UNPUBLISHED. RELEASED FOR PUBLICATION  
 © COPYRIGHT BY TYCO ELECTRONICS CORPORATION. ALL RIGHTS RESERVED.

LOC	DIST	REVISIONS					
G	14	P	LTR	DESCRIPTION	DATE	DWN	APVD
				REV PER ECR 07-030708	27DEC07	JR	TM

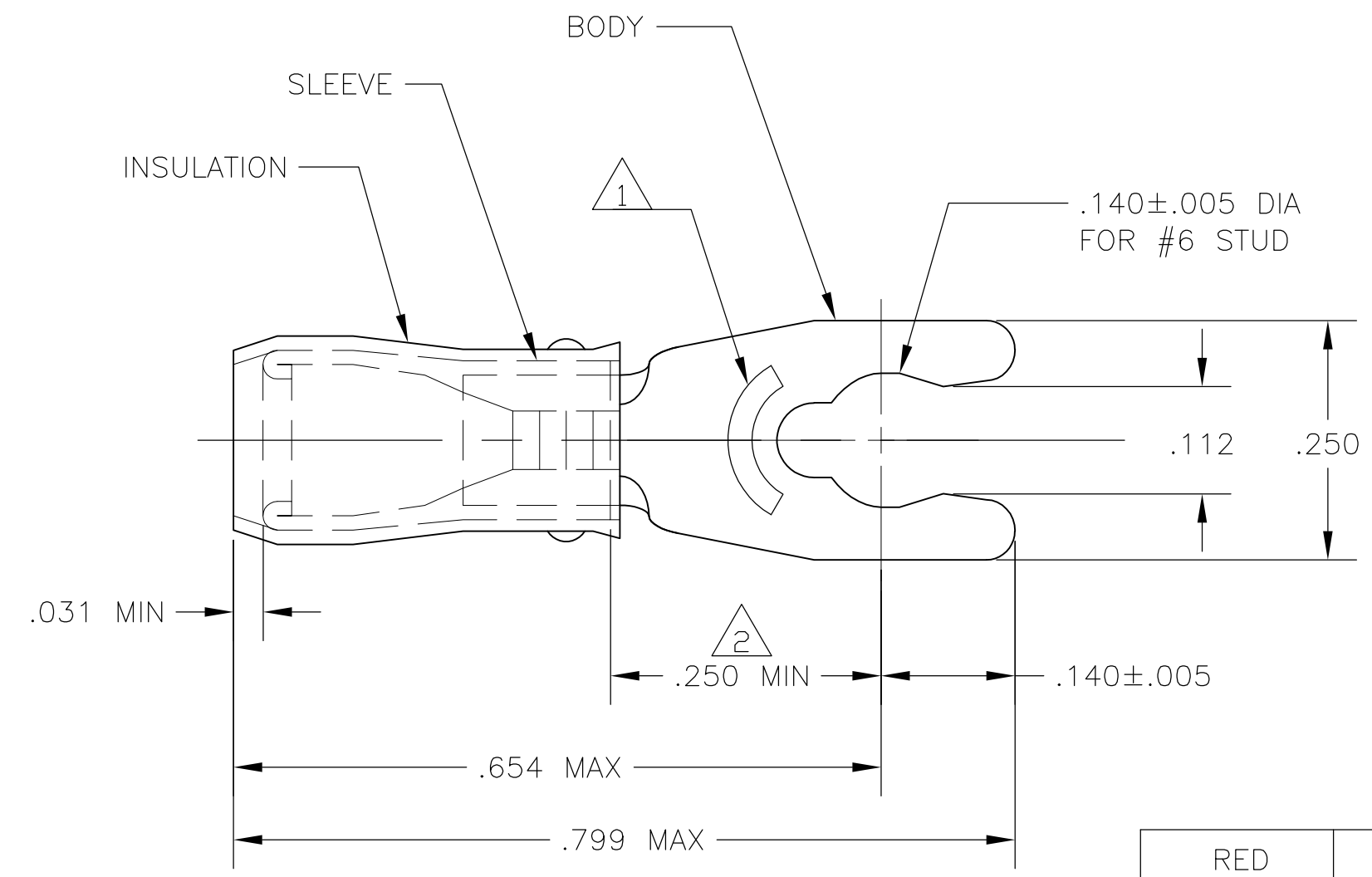

- 1 STAMP 6S AMP 22-18\*, APPROX AS SHOWN. 22-16 TERMINALS ARE STAMPED 22-18 IN ACCORDANCE WITH MILITARY SPEC MIL-T-7928, COMMERCIAL WIRE RANGE IS 22-16.
- 2 APPLIES FROM EDGE OF METAL WIRE BARREL TO CENTER OF STUD HOLE.
- 3 TONGUE MATERIAL THK IS .031±.002
- 4 BODY - COPPER PER ASTM B-152 INSULATION - COPPER PER ASTM B-152 SLEEVE - NYLON
- 5 BODY - TIN PLATE PER MIL-T-10727 INSUL. - TIN PLATE PER MIL-T-10727 SLEEVE - SEE TABLE

<b>AMP</b> WIRE RANGE	Listed FILE E13288	LR7189 Certified
22-16 AWG SOLID OR STRANDED	22-16 AWG SOLID OR STRANDED	22-16 AWG SOLID OR STRANDED

RED	.080-.125	100	LOOSE PIECE, BOX	8-52929-1
BLACK	.080-.125	5000	ON TAPE, REEL	1-52929-0
RED	.105-.140	5000	ON TAPE, REEL	52929-3
RED	.080-.125	5000	ON TAPE, REEL	52929-1
RED	.080-.125	1000	LOOSE PIECE	52929
INSULATION COLOR	WIRE INSULATION OD	QTY	PACKAGE TYPE	PART NO

<b>AMP INCORPORATED CUSTOMER SERVICE SYSTEMS</b>		MAX RECOMMENDED OPERATING TEMPERATURE: 105°C	THIS DRAWING IS A CONTROLLED DOCUMENT.		DWN jr_ruth 01MAY07	Tyco Electronics Corporation Harrisburg, PA 17105-3608			
FOR ADDITIONAL PRODUCT INFORMATION OR COPIES OF DRAWINGS AND TECHNICAL DOCUMENTS	PRODUCT INFORMATION CENTER 1-800-522-6752	VOLTAGE RATING: 300 V MAX	DIMENSIONS: INCHES	TOLERANCES UNLESS OTHERWISE SPECIFIED:	CHK T MICHELUTTI 01MAY07	NAME T MICHELUTTI			
FOR APPLICATION TOOLING INFORMATION	TOOLING ASSISTANCE CENTER 1-800-722-1111	CIRCULAR MIL AREA: 0.26-1.65mm² [509-3260] SOLID OR STRANDED		0 PLC ± - 1 PLC ± - 2 PLC ± - 3 PLC ± .008 4 PLC ± - ANGLES ± 5°	APVD T MICHELUTTI 01MAY07	PRODUCT SPEC -			
FOR ORDER ENTRY	1-800-526-5142	THIS DRAWING IS A CONTROLLED DOCUMENT FOR AMP INCORPORATED. IT IS SUBJECT TO CHANGE AND THE CONTROLLING ENGINEERING ORGANIZATION SHOULD BE CONTACTED FOR THE LATEST REVISION.	MATERIAL - 4	FINISH - 5	APPLICATION SPEC -	SIZE A3	CAGE CODE 00779	DRAWING NO G-52929	RESTRICTED TO -
CUSTOMER DRAWING					SCALE 6:1	SHEET 1 OF 1	REV N2		